

# HSF

NOTES:  
 Rated Current: 3.0AMP.  
 Contact Resistance: 20mΩ Max.  
 Withstand Voltage: 1000V AC/DC  
 Insulation Resistance: 1000MΩ Min.  
 Operation Temperature: -40℃ to +105℃

Contact Material: Brass  
 Contact Plating: Au or Sn Over Ni  
 Insulator Material: PA9T+33%G.F UL94V-0 BK

A2

## Ordering Information

1125-21 XX XX R XXX C 0 XX

No. of Pins: 02-40  
 Contact Plating: G0=Gold Flash, G3=10u"Gold, G4=15u"Gold, G5=30u"Gold, S0=Gold Flash/Tin, S3=10u"Gold/Tin, S4=15u"Gold/Tin, S5=30u"Gold/Tin, SN=Tin, SM=Matte Tin  
 Pin Length: L=A+B+D1+D2+5.3 Standard:  
 Insulator Material: C=PA9T  
 Packing: 0=PE Bag, T=Tube  
 Series No.: 01-99

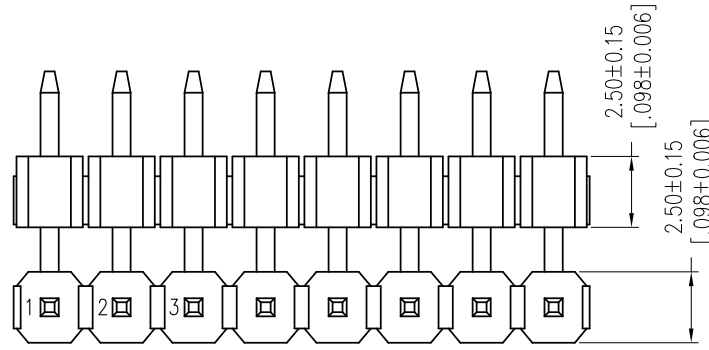

Recommended P.C.B Layout (Top Side)  
 (PCB BOARD TOLERANCE±0.05)

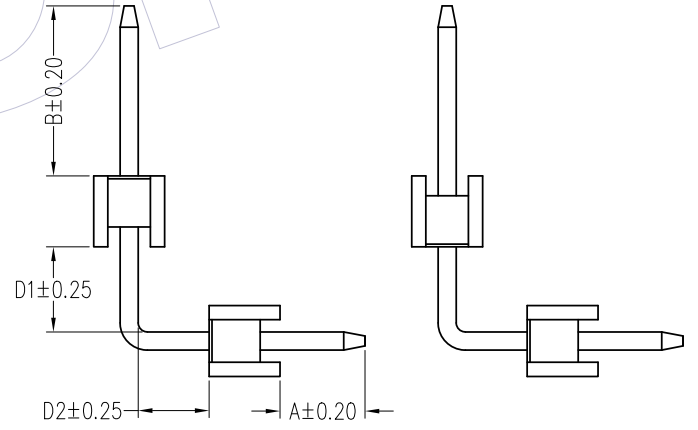
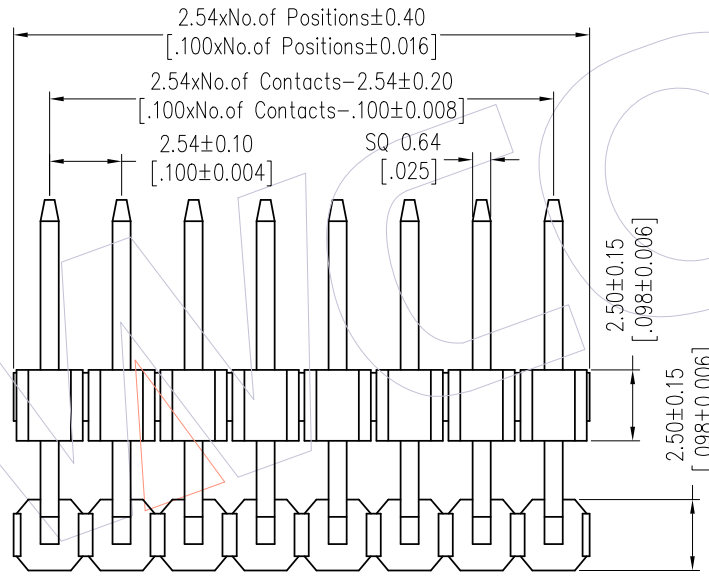
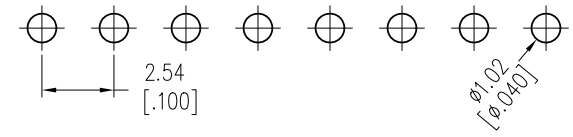

Item	Pin Length	A	D1	B	D2	Mating
Standard	---	3.00	---	6.00	---	2171 2185
Alternate						

REV	DATE	MODIFICATION DESCRIPTION	CHANGE	OPERATION	DRAW	DATE	SCALE	Fit	PART NO.
A2	2018/06/02	Cancel PBT & Modify P/N	A2	x.x ±0.40	XSR	2018/06/02	UNIT	mm	1125-21XXXXXXC0XX A1 A2
A1	2018/01/22	Modify P/N	A1	x.xx ±0.25	CHECK	DATE	SIZE	A4	TITLE: PH2.54 SINGLE ROW DOUBLE PLASTIC 90° MIDDLE BENDING H=2.5
A0	2012/05/17	NEW	----	x.xxx ±0.15	APPROVE	DATE	SHEET	1/1	Customer NO.
				Angle ± 3°			PROJ.		
				DIM TOL					

**WCON**  
 Http: www.wcon.com  
 WCON-Dongguan Tel: +86 769 85358920 Fax: +86 769 85358915 E-mail: sales@wcon.com  
 WCON-Kunshan Tel: +86 512 57468408 Fax: +86 512 57468468 E-mail: salesks@wcon.com