

HSF

Recommended P.C.B Layout(Top Side)
(PCB BOARD TOLERANCE±0.05)

NOTES:

Rated Current: 3.0AMP
 Rated Voltage: 12V DC
 Contact Resistance: 30mΩ max
 Withstand Voltage: 1000V AC/DC
 Insulation Resistance: 5000MΩ min
 Operation Temperature: -55℃ to +105℃

Contact Material: Copper Alloy
 Contact Plating: Au Over Ni
 Insulator Material: High Temperature Thermoplastic(UL94V-0)

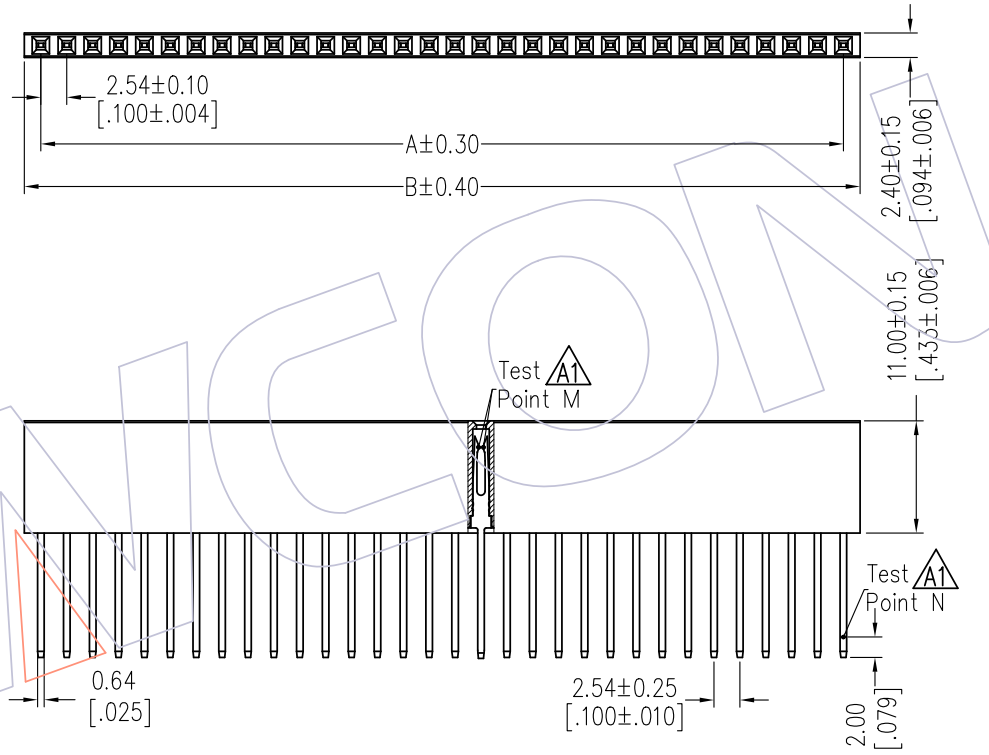
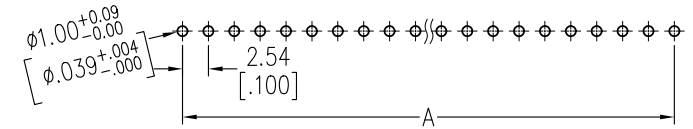

Contact Plating	Test Point M	Test Point N
G1	3U"	3U"
G3	10U"	10U"
G4	15U"	15U"
H3	10U"	3U"
H4	15U"	3U"

Ordering Information

2111A - 1 XX S XX F Y N T 1

No. of Pins per
20P
32P

Contact Plating:
G1=Fully 3u"Gold
G3=Fully 10u"Gold
G4=Fully 15u"Gold
H3=Mating 10u"Gold
Tail 3u"Gold
H4=Mating 15u"Gold
Tail 3u"Gold

Packing:
T=Tube

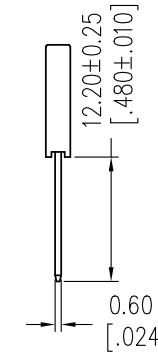

Item	Pitch	Mating
Standard	2.54	1125
Alternate		

ITEM	Dim A	Dim B	Pcs/Tube
1*20P	48.26	51.52	11
1*32P	78.74	82.00	7

REV	DATE	MODIFICATION DESCRIPTION	CHANGE	OPERATION	DRAW XSR	DATE	SCALE	FIT	PART NO.
A1	2019/12/30	MODIFY	-----	x.x ±0.40	CHECK	2019/12/30	UNIT mm	A4	2111A-1XXSXXFYNT1
A0	2012/08/20	NEW	-----	x.xx ±0.25	APPROVE		SIZE A4	1/1	TITLE: 2.54mm PC104 1*20P/1*32P 180°DIP H=11.0 DIP=12.2
				x.xxx ±0.15			SHEET 1/1		Customer NO.
				Angle ± 3°			PROJ.		
				DIM TOL					

WCON
 Http: www.wcon.com

WCON-Dongguan
 Tel: +86 769 85358920
 Fax: +86 769 85358915
 E-mail: sales@wcon.com

WCON-Kunshan
 Tel: +86 512 57468408
 Fax: +86 512 57468468
 E-mail: sales@wcon.com