

HSF

NOTES:

Rated Current: 3.0AMP
 Rated Voltage: 12V DC
 Contact Resistance: 30mΩ max
 Withstand Voltage: 1000V AC/DC
 Insulation Resistance: 5000MΩ min
 Operation Temperature: -55℃ to +105℃
 Contact Material: Copper Alloy
 Contact Plating: Au Over Ni
 Insulator Material: High Temperature Thermoplastic(UL94V-0)

Ordering Information

2111A-2 XX S XX F Y N T 2

No. of Pins per
 20P
 32P
 52P(20+32P)

Contact Plating:
 G1=Fully 3u"Gold
 G3=Fully 10u"Gold
 G4=Fully 15u"Gold
 H3=Mating 10u"Gold
 Tail 3u"Gold
 H4=Mating 15u"Gold
 Tail 3u"Gold

Packing:
 T=Tube

ITEM	Pcs/Tube
2*20P	11
2*32P	7
2*52P	7

Item	Pitch	Mating
Standard	2.54	1125
Alternate		

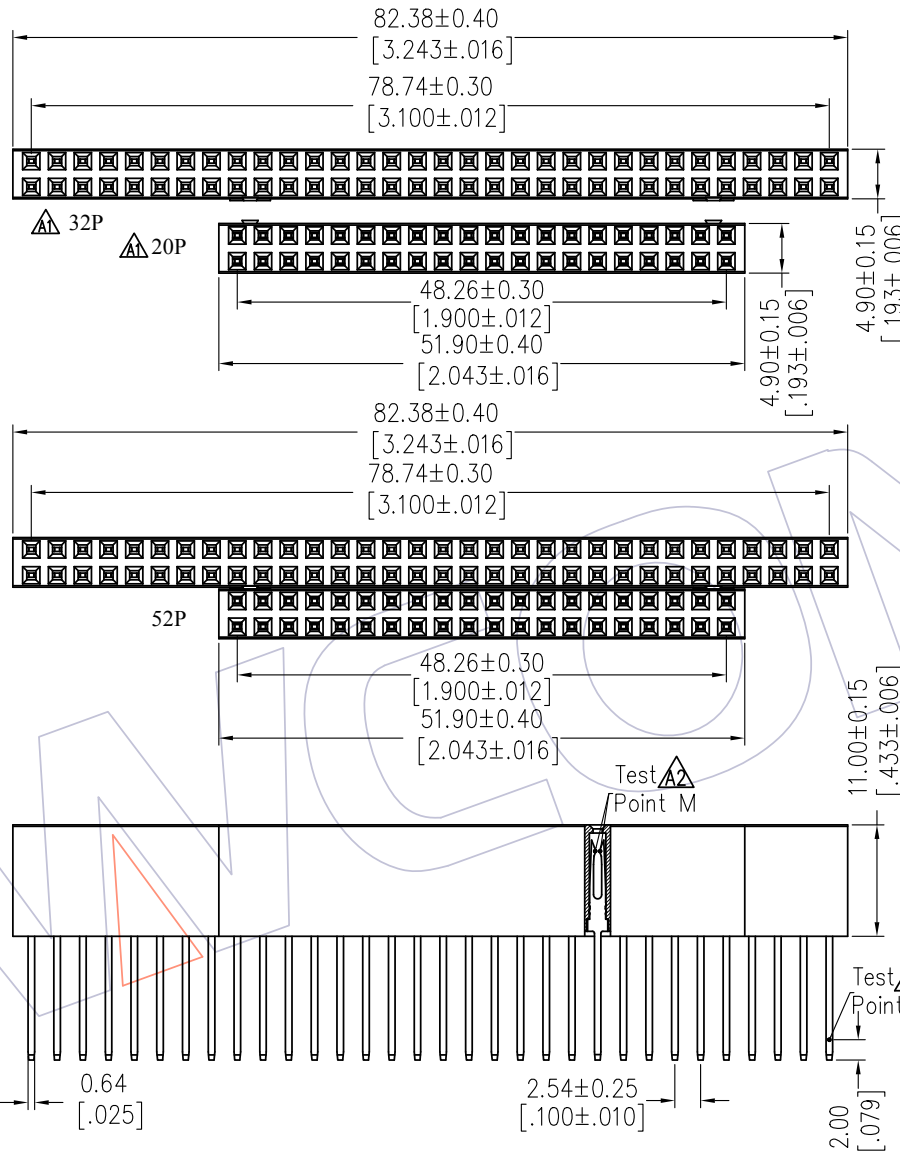
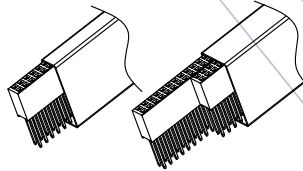

Recommended P.C.B Layout(Top Side) (PCB BOARD TOLERANCE±0.05)

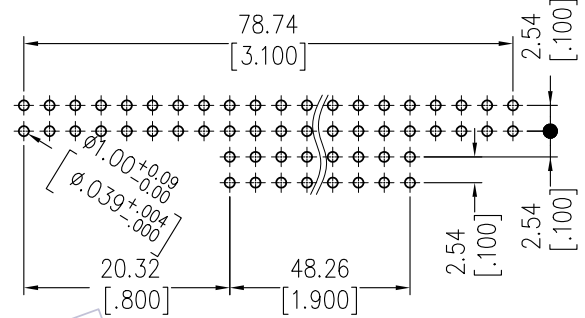

Contact Plating	Test Point M	Test Point N
G1	3U"	3U"
G3	10U"	10U"
G4	15U"	15U"
H3	10U"	3U"
H4	15U"	3U"

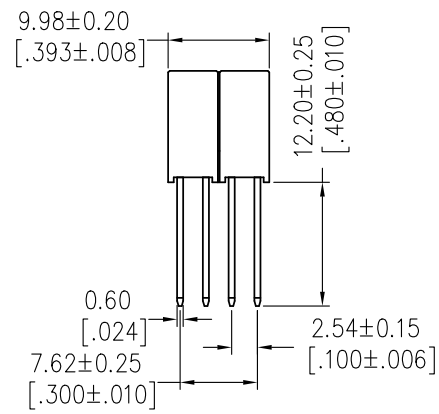

REV	DATE	MODIFICATION DESCRIPTION	CHANGE	OPERATION	DRAW	DATE	SCALE	FIT	PART NO.
A2	2019/12/30	MODIFY	△△	x.x ±0.40	XSR	2019/12/30	UNIT	mm	2111A-2XXSXXFYNT2
A1	2019/06/11	ADD 52P&20P 32P VIEW	△△	x.xx ±0.25	CHECK	DATE	SIZE	A4	TITLE: 2.54mm PC104 2*XXP 180° H=11.0 DIP=12.2
A0	2012/08/20	NEW	----	x.xxx ±0.15	APPROVE	DATE	SHEET	1/1	Customer NO.
				Angle ± 3°			PROJ.		
				DIM TOL					

WCON
 Http: www.wcon.com

WCON-Dongguan
 Tel: +86 769 85358920
 Fax: +86 769 85358915
 E-mail: sales@wcon.com

WCON-Kunshan
 Tel: +86 512 57468408
 Fax: +86 512 57468468
 E-mail: salesks@wcon.com